

Volumetric Dosers

SCM series volumetric dosers are suitable for auto - proportional mixing of new materials, regrinds, masterbatch or additives. A brushless DC motor is used in this series. According to the set mixing proportion, the microprocessor accurately controls rotation of the high precise dosing screw to squeeze out materials with an accuracy of $\pm 1\%$. A gear motor with gear ratio of 38 : 1 or 75:1 is coupled to a dosing screw of 12, 14 or 16mm diameter to give a total of six models with output ranging from 0.1 ~ 32 kg / hr. Double color dosers can be assembled from two single color dosers if required.



SCM-38 Single Color Doser

Features

- Use brushless DC motor and free from maintenance.
- Everlasting data memorizer and settings storage.
- Microprocessor control, intelligent and accurate in calculation.
- External signals can be directly interfaced with control box.
- Dosing screws are chrome plated for durability.
- Unit is comprised of standard modules for ease of cleaning, disassembly and interchangeability.
- Three - tube hopper magnet is equipped at the base of single color doser to absorb metal impurities so to prevent screw of moulding machine from damage.
- Blender is a standard accessory for double color doser to make the material evenly mixed, while also a optional accessory for single color doser to do so.
- Main material hopper is a standard accessory for double color doser. It is optional for single color doser.
- When work with SHD - 100 or models above SHD - 160U, installation base should have an additional large flange mounted on (without three - tube hopper magnet).
- For SHD - 100 ~ 300KG and SHD - 160U ~ 450U, floor stands should be selected.
- Upon request, it can be built to comply with worldwide electrical safety standards (For example : CE, UL, CSA, JIS etc.).



SCM-D-38 / 38 Double Color Dosers

Outline Drawings

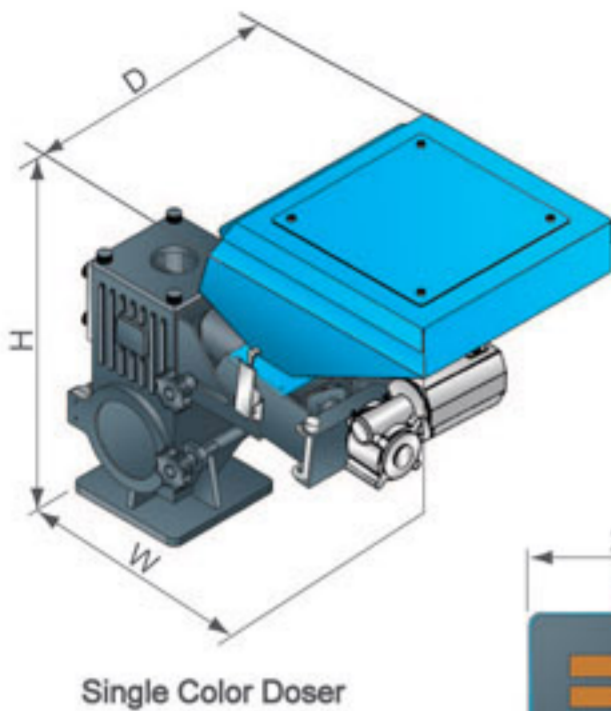

Single Color Doser

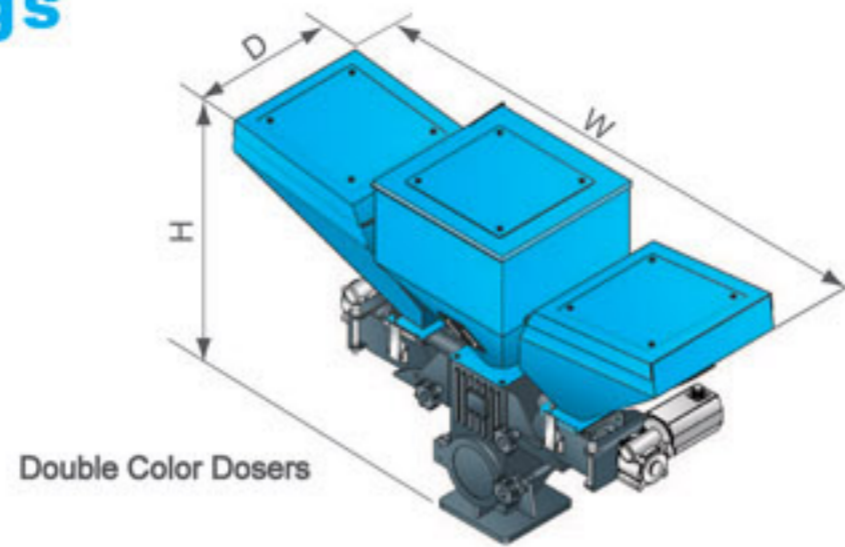

Double Color Dosers

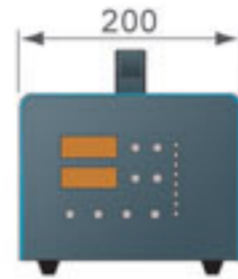

Front Picture of Control Box

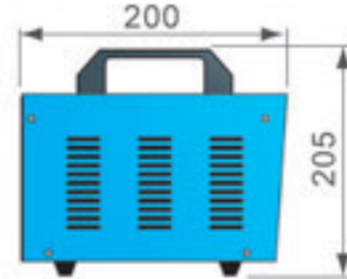

Side Picture of Control Box

Optional

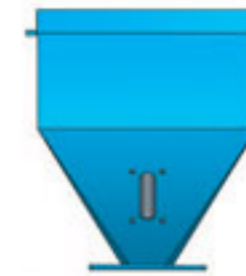

Main Material Hopper

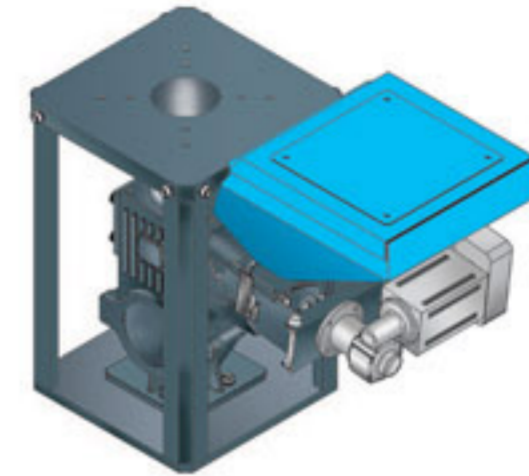

Demonstration after Floor-Stand Mount on

Specifications

Model	Single Color Unit						Double Color Unit		
	SCM-38-16	SCM-38-14	SCM-38-12	SCM-75-16	SCM-75-14	SCM-75-12	SCM-D-38 / 38	SCM-D-38 / 75	SCM-D-75 / 75
Motor Power (kW) (50 / 60Hz)	0.06	0.06	0.06	0.06	0.06	0.06	0.06 × 2	0.06 × 2	0.06 × 2
Motor Speed (r.p.m.)	0~3000	0~3000	0~3000	0~3000	0~3000	0~3000	0~3000	0~3000	0~3000
Output Power of Mixer (kW, 50 / 60Hz)	0.09	0.09	0.09	0.09	0.09	0.09	0.09	0.09	0.09
Screw External Dia. (mm)	16	14	12	16	14	12	**	**	**
Output Capacity (kg / hr)	1.1~32	0.6~20	0.3~10	0.5~15	0.2~8	0.1~4	*	*	*
Storage Bin (L)	10	10	10	10	10	10	10	10	10
Gear Ratio	38:1	38:1	38:1	75:1	75:1	75:1	38:1 / 38:1	38:1 / 75:1	75:1 / 75:1
Main Material Hopper	Optional	Optional	Optional	Optional	Optional	Optional	Standard	Standard	Standard
Mixer	Optional	Optional	Optional	Optional	Optional	Optional	Standard	Standard	Standard
Floor Stands	Optional	Optional	Optional	Optional	Optional	Optional	Optional	Optional	Optional
Dimensions									
H (mm)	520	520	520	520	520	520	615	615	615
W (mm)	610	610	610	610	610	610	1045	1045	1045
D (mm)	335	335	335	335	335	335	335	335	335
Weight (kg)	29	29	29	29	29	29	50	50	50

Note: 1) "*" means the output capacity depends on model selected, data of the single color doser can be a reference. For example: SCM-D-38-16 / 38-14, output capacity 1.7 ~ 52 kg / hr.

2) "**" stands for external dia. of screw is up to model selected.

3) All output capacities from above models are base on data from density 1.2, dia. 2 ~ 3 mm masterbatch in a test criteria of continuous running.

4) Main power for single color unit is 1Φ, 115 / 230V, 50 / 60Hz, but it will be 3Φ, 230 / 400 / 460 / 575V, 50 / 60Hz when equipped the mixer.

5) For additionally mount mixer on single color doser, add "MS" at model behind.

We reserve the right to change specifications without prior notice.

SHINI PLASTICS TECHNOLOGIES, INC.

Corporate Strategic Center

Overseas Business Department:

Dalang, Dongguan, Guangdong, China

Tel: (0769) 8111 6600

Fax: (0769) 8111 6611

Email: shini@shini.com