

Air-cooled Central Water Chillers

SICC-A series air-cooled central chillers utilize hermetic scroll compressor as main body, thus having excellent technical characteristics and are suitable for various cooling media, such as R22 and R407C. The famous brand of motor of the fans offer high efficiency and water-proof. The good quality copper made tube-fin condenser features excellent heat exchange capacity. It is also controlled by advanced microcomputer controller which has greater function and better performance than the single chip based unit in chilling industry.



LCD Control Panel



SICC-90A

Features:

- Modularized design makes it easier to combine module units 1 to 15. Cooling capacity can be enlarged by increasing the number of modules or choose appropriate modules to connect to existing system.
- The water route of the modules can be linked via linking one module to the inlet/outlet water tube. No need to install the inlet/outlet water tube for each module alone. The soft rubber tube is used to connect the modules, thus it is very convenient to construct.
- The unit of the module is compact in structure, easier for maintenance and can be installed either with no between space or some between space according to the construction needs.
- Adopts imported components like scroll compressor, expansion valve which ensure stable performance. The whole unit will not stop due to one module failure.
- When the whole unit is running, the microcomputer will auto adjust the performance of each module or open / shut respective module unit according to system load. The module unit adopts double compressors and its power adjustable range is enlarged after combination to save up power whenever possible.
- Optional RS 485 communication realize the remote monitoring and network function.
- Wired control system enables the main unit and its controller to be separated from each other.

SICC-A Series

1、Outline Drawings

SICC-60A

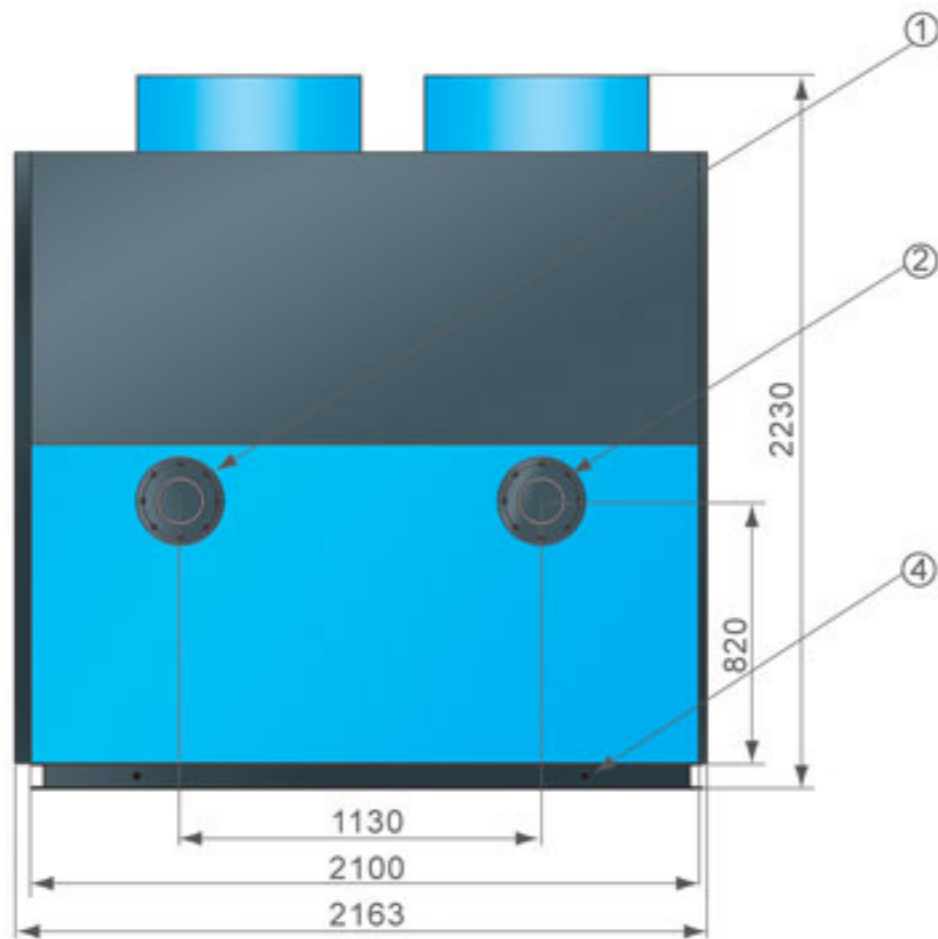
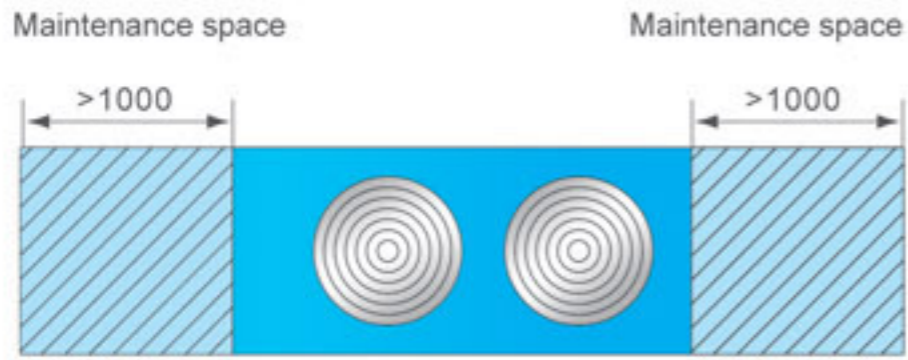

- | | |
|--------------|----------------------|
| 1. 5B | Cooling water outlet |
| 2. 5B | Cooling water inlet |
| 3. $\Phi 16$ | Bearing hole |
| 4. M16 | Stationary ring bolt |

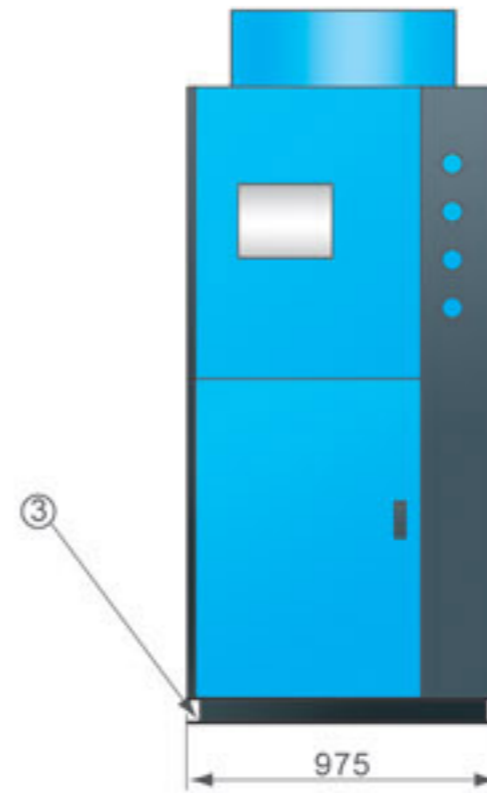

SICC-90A

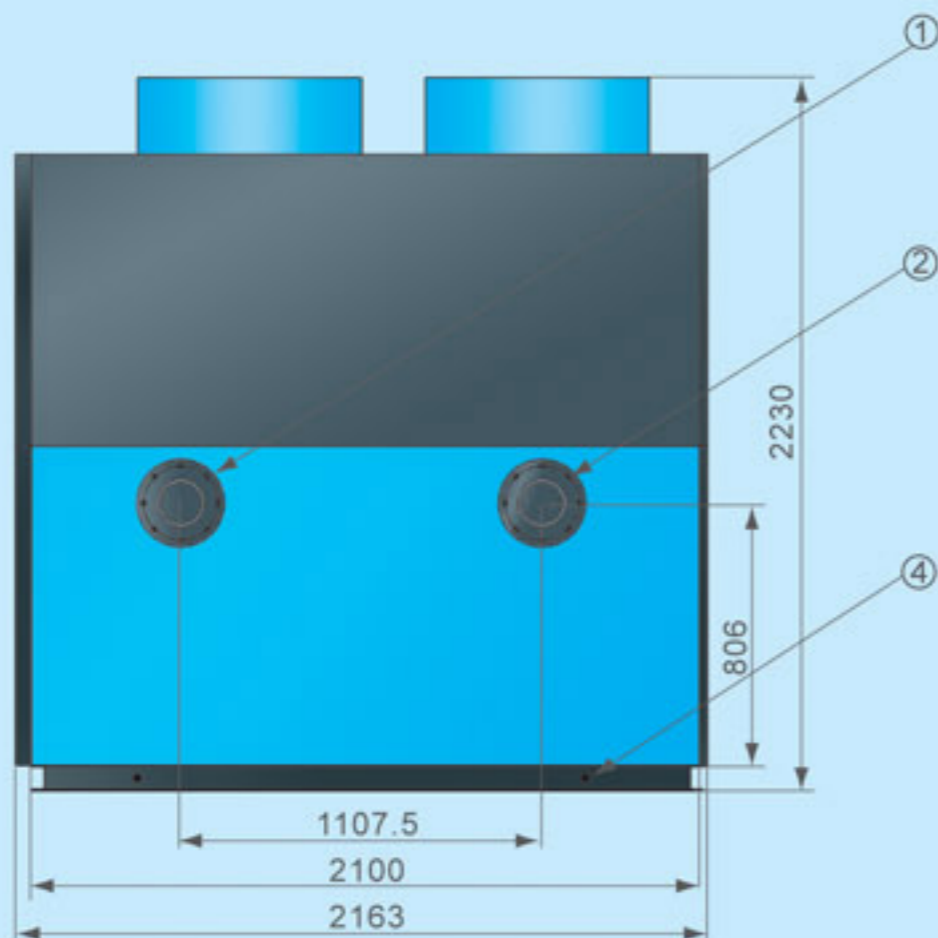
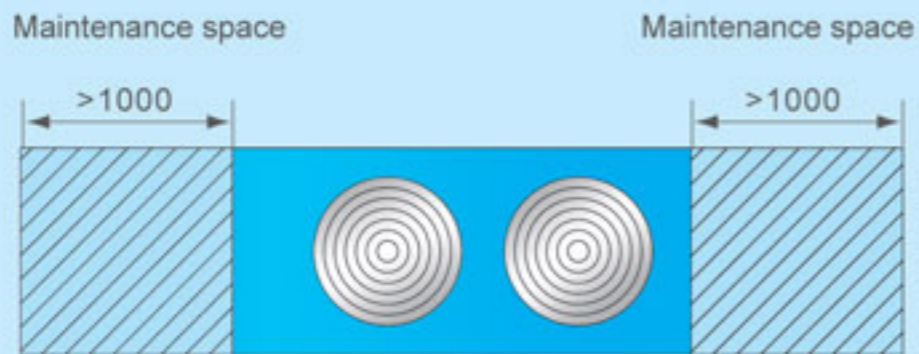

- | | |
|--------------|----------------------|
| 1. 5B | Cooling water outlet |
| 2. 5B | Cooling water inlet |
| 3. $\Phi 16$ | Bearing hole |
| 4. M16 | Stationary ring bolt |

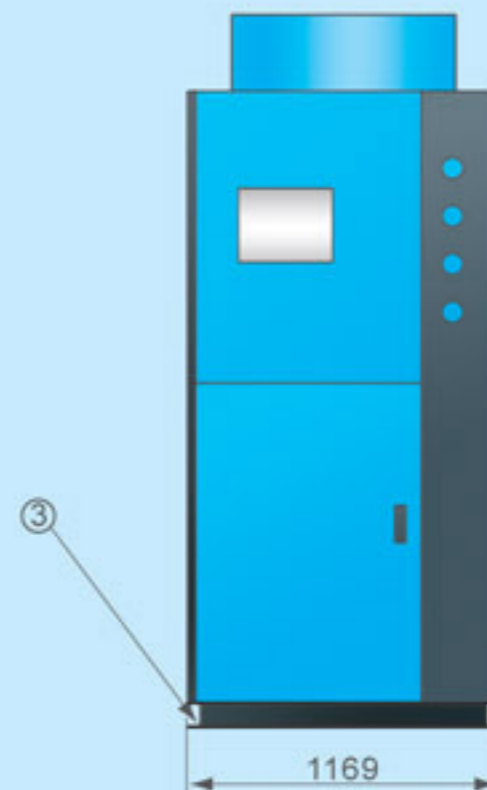

SICC-120A

Maintenance space

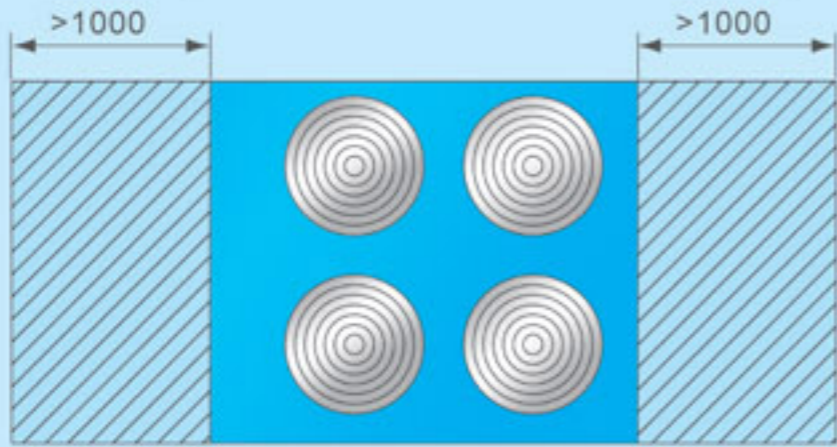

Maintenance space

- | | | |
|--|--------------|----------------------|
| | 1. 5B | Cooling water outlet |
| | 2. 5B | Cooling water inlet |
| | 3. $\Phi 16$ | Bearing hole |
| | 4. M16 | Stationary ring bolt |

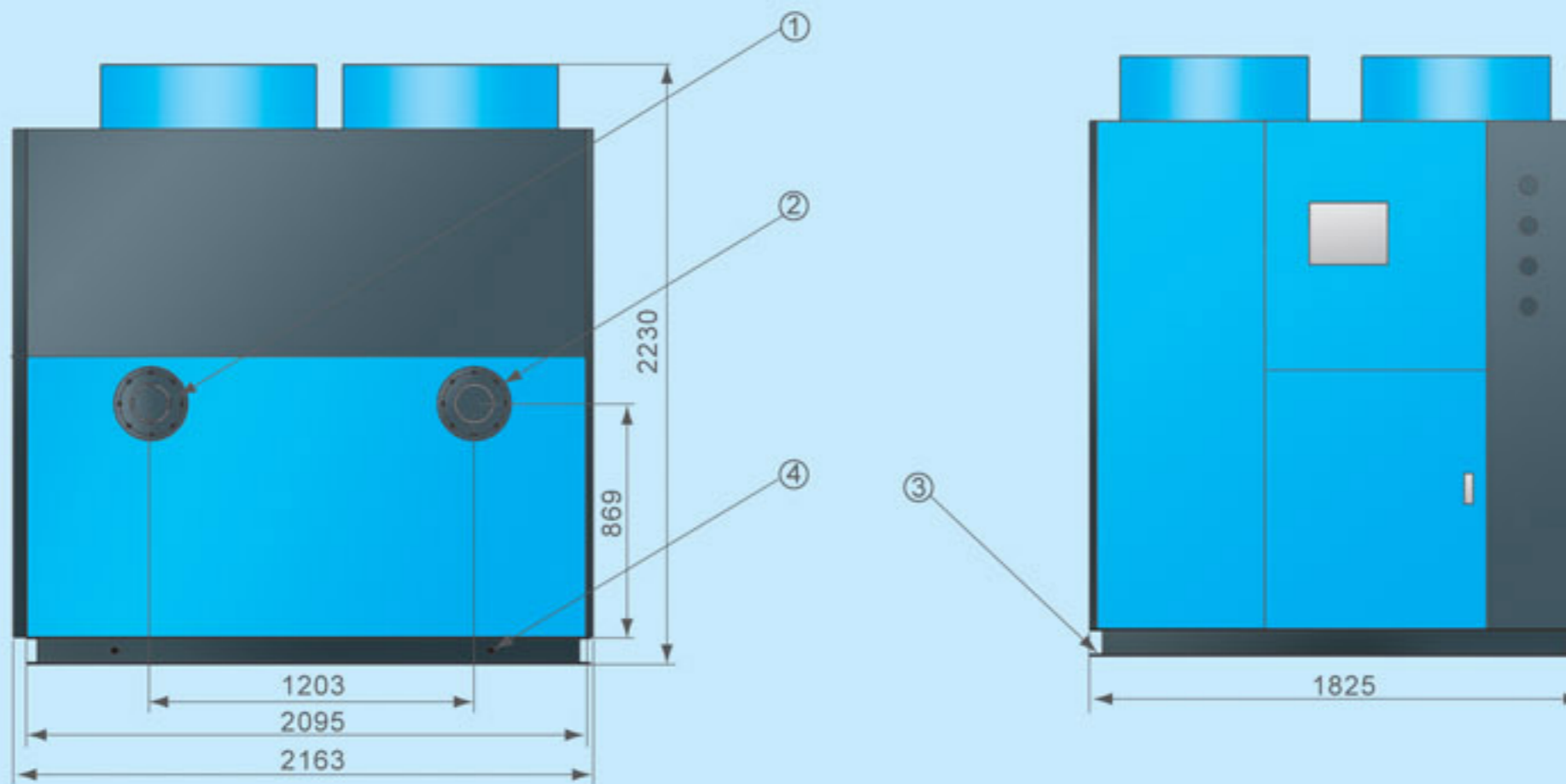

2、Working Principle

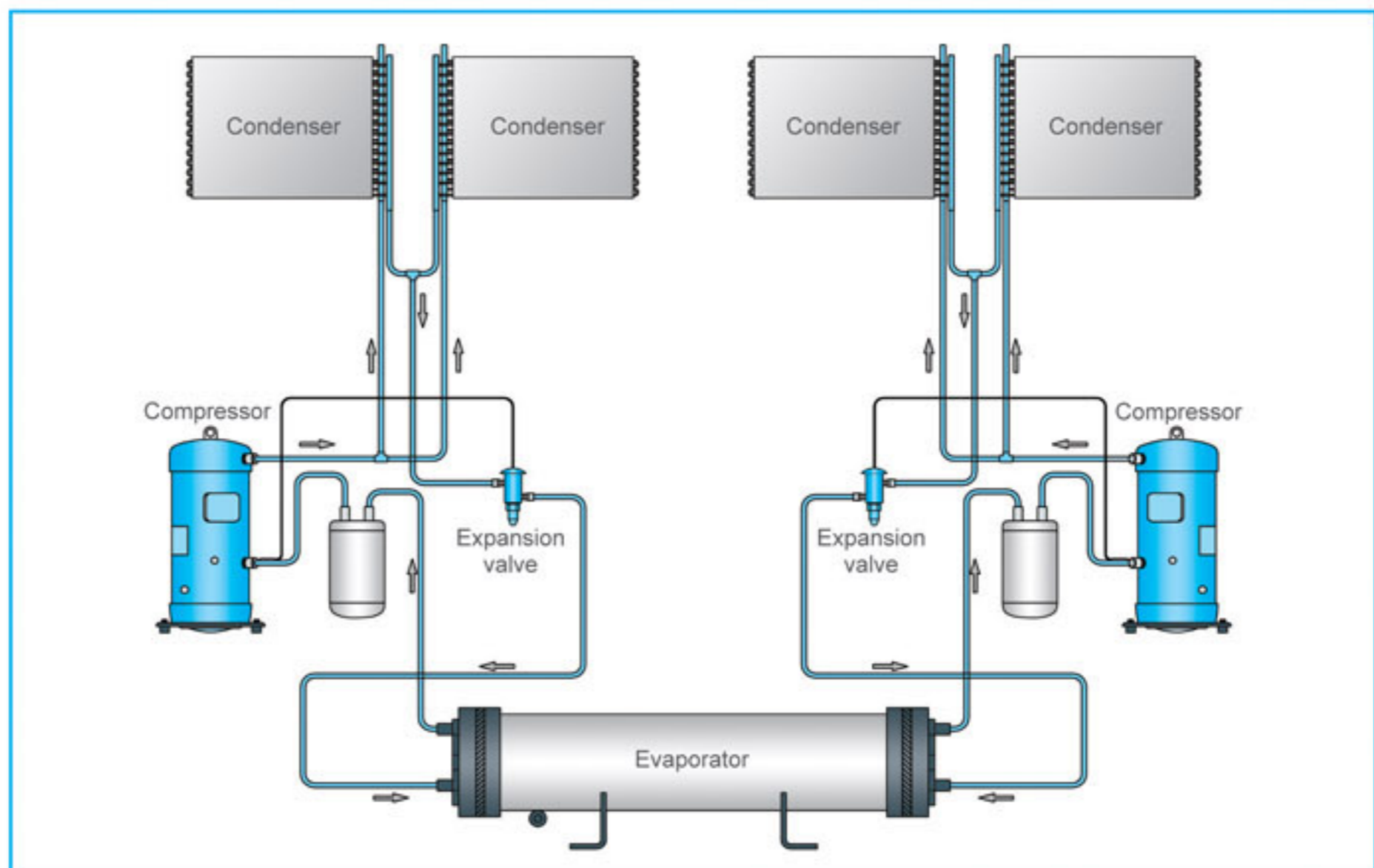

3、 Specifications

Items		Model	SICC-60A	SICC-90A	SICC-120A
Cooling Power	kW		60	90	120
	kcal / h		51600	77400	103200
Power	---		3Φ, 400 / 460V, 50 / 60Hz		
Total Power	kW		19	28	37
Running Current	A		33	48	61
Startup Current	A		140	175	230
Compressor	Type	---	Hermetic Scroll		
	Power	kW	8.5 X 2	13.6X 2	18.8 X 2
	Crank Case Heater	kW	0.07 X 2	0.07 X 2	0.09 X 2
Refrigerant	type	---	R22 (R407C Optionaly Available)		
	filling quantity	kg	15	18	36
Axial flow	type	---	Closed Shell and Tube Evaporator		
	cooling flow	m ³ / h	10.3	15.5	20.6
	pressure loss	kPa	27	39.2	49
	water coupler	inch	5"	5"	5"
Condenser	type	---	Tube-fin Air-cooled Condenser		
	blower power	kW	1.68	1.68	3.72
	air quantity	m ³ / h	26000	39000	52000
Machine Dimensions	Width (W)	mm	2163	2163	2163
	Depth (D)	mm	975	1170	1825
	Height (H)	mm	2230	2230	2230
Weight	Before Packing	kg	720	820	1300
	After Packed	kg	760	870	1350
Noise Level dB(A)	dB(A)		71	72	74

Note: 1) The cooling power refers to the following conditions: out door dry bulb temperature 35 °C, temperature at cooling water inlet is 12 °C and 7 °C at its outlet.

2) Change to use R407C environment friendly refrigerant is available as option, but the refrigeration capacity can be decreased by 5%.

4、Module Combination Table

Type	Model	Grouping	Compressor Power (kW)
Module Model	SICC-60A	60A	17
	SICC-90A	90A	27.24
	SICC-120A	120A	37.56
Module Unit	SICC-150A	60A + 90A	44.24
	SICC-180A	2 × 90A	54.48
	SICC-210A	90A + 120A	64.8
	SICC-240A	2 × 120A	75.12
	SICC-270A	3 × 90A	81.72
	SICC-300A	2 × 90A + 120A	92.04
	SICC-330A	3 × 90A + 60A	98.72
	SICC-360A	3 × 120A	112.68

Type	Model	Grouping	Compressor Power (kW)
Module Unit	SICC-420A	4 × 90A + 60A	125.96
	SICC-450A	5 × 90A	136.2
	SICC-480A	4 × 120A	150.24
	SICC-540A	6 × 90A	163.44
	SICC-570A	4 × 120A + 90A	174.48
	SICC-600A	5 × 120A	187.8
	SICC-660A	5 × 120A + 60A	204.8
	SICC-720A	6 × 120A	225.36
	SICC-780A	6 × 120A + 60A	242.36
	SICC-840A	7 × 120A	262.92
	SICC-930A	7 × 120A + 90A	287.16
	SICC-990A	7 × 120A + 90A + 60A	294.16

We reserve the right to change specification without prior notice.

5、Foundation and Installation

5a、Select Installation Site

- 1) No heat source exists nearby to avoid efficiency reduction due to hot air absorbing.
- 2) No impact imposed by high temperature, vapor or oil stain.
- 3) Avoid being spattered by water vapor when choosing installation site near cooling water tower so to avoid any short circuit or creepage.
- 4) Proper ventilation without hindrance for air inhaled or exhaled.
- 5) No existence of inflammable substance.
- 6) When using concrete bearing platform, the platform must be firm and flat. Install shock proof mat in the bolt of bearing platform if necessary.
- 7) Set apart some service space. Space ranges are recommended as shown in figure 6 - 1.

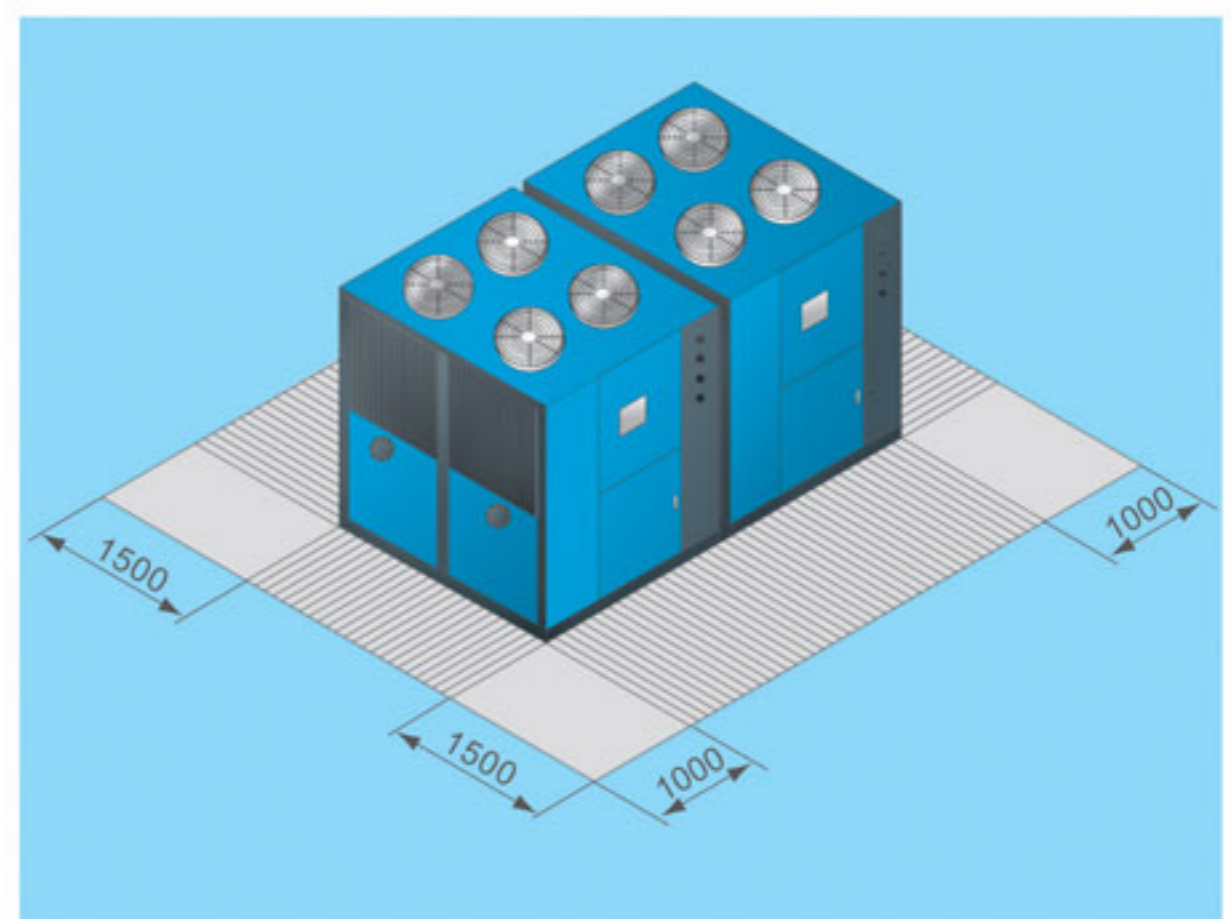
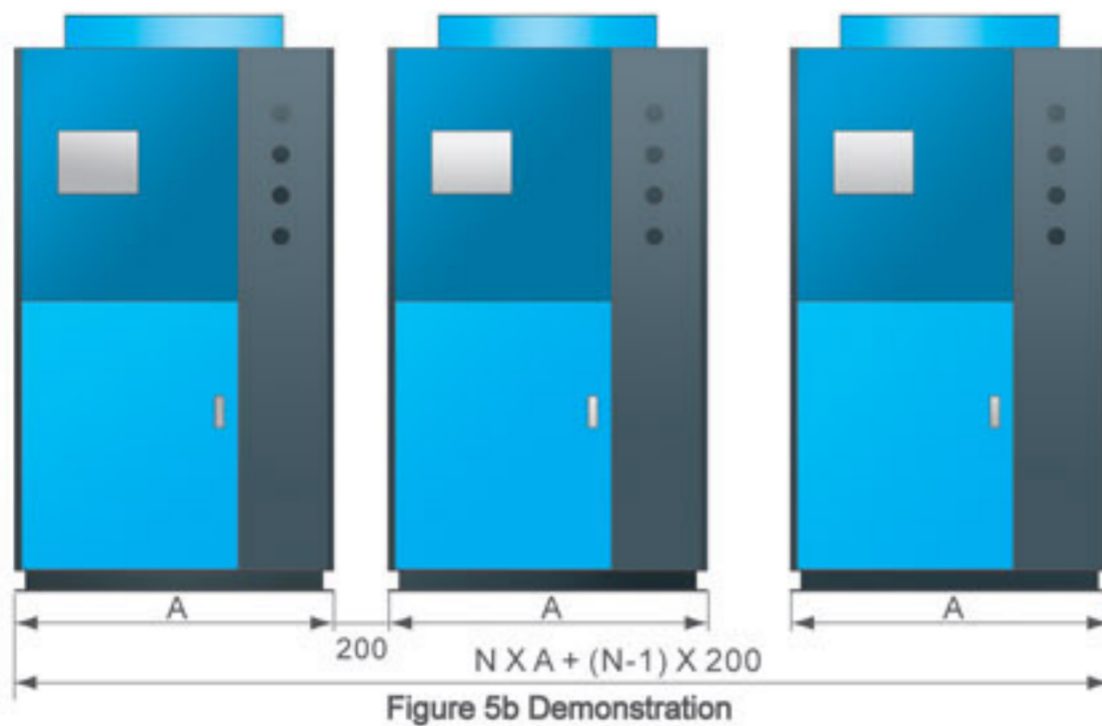

Figure 5a Installation Space Unit: mm

5b、 Installation Demonstration



Type	Module Model	Model Dimension(A)	Combination Size
Module Unit	SICC-60A	975	N X A + (N-1) X 200
	SICC-90A	1170	
	SICC-120A	1825	

Note: module unit can realize no between space installation and refer to figure 5b for guidance. Unit: mm

5c、 Bearing Platform

- 1) The unit should be installed on concrete or steel structure bearing platform that is firm and the surface of the bearing platform should be smooth and flat. The intensity of the platform should hold the whole unit, if the intensity is not strong enough, it is easy to cause vibration or noise.
- 2) The surface of the concrete base platform normally has been plastered as horizontal ornament, with waterproof treatment. The surrounding of it should have drainage sink placed, and the slope angle should be no less than 0.5%, and the slope should lead to drainage outlet.
- 3) In order to maintain quiet operation and prevent the vibration and noise transmission from interfering the under floors, the absorber should be laid between the unit base and base platform. Please maintain horizontal when install the unit and mount antivibration pad when it is necessary.
- 4) In order to keep connection pipe from being twisted to crack by earthquake, typhoon, or by long time running caused movement. The fixation method should be taken into consideration, refer to following examples for platform installation and fixation:

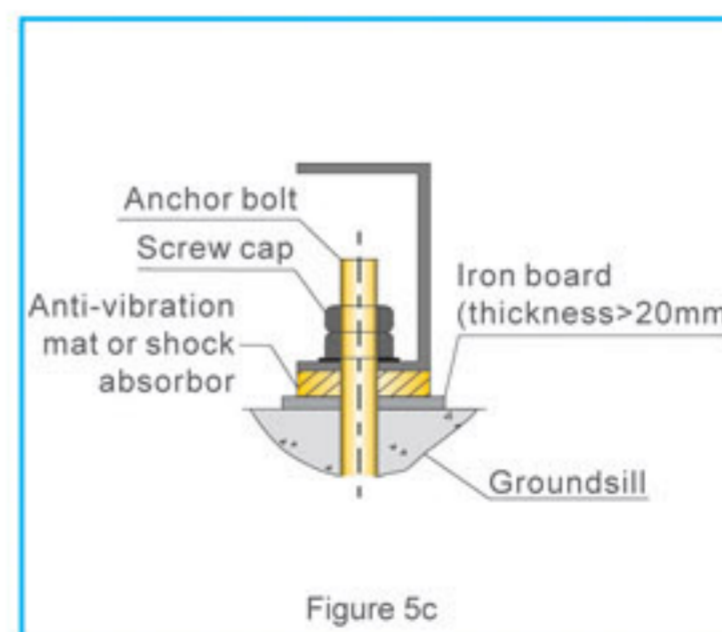
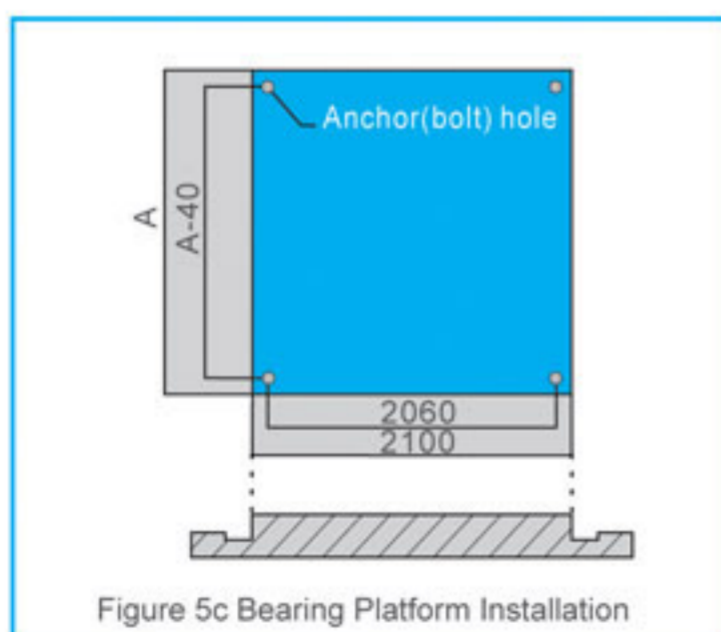

SHINI PLASTICS TECHNOLOGIES, INC.

Corporate Strategic Center
 Overseas Business Department:
 Dalang, Dongguan, Guangdong, China
 Tel: (0769) 8111 6600
 Fax: (0769) 8111 6611
 Email: shini@shini.com