

Dual-purpose Water / Oil Heaters

STM - W/O series of dual - purpose heaters are mainly used to heat up the mould and maintain its temperature, although they can be also used in other similar applications. High temperature water or oil return from the mould is cooled by indirect cooling and then sent to the pipe heaters via high - pressure pump for heating to a constant temperature. This unique design allows user to choose between water and oil as heat transfer medium. With our optimised design, the OMRON temperature controller can maintain an accuracy of $\pm 1^\circ\text{C}$.



STM-1207-W/O Control Panel



STM-1207W/O

Features:

- P.I.D. multi - stage temperature control system can maintain a mould temperature with accuracy of $\pm 1^\circ\text{C}$.
- Adopt high efficiency, high temp. vertical dual - purpose pump to ensure stable performance and great pressure.
- Multiple safety devices can automatically detect abnormal performance and indicate this via visible alarm.
- Attractive appearance, easy to access and maintain.
- Inner parts made from stainless steel to ensure corrosion - free operation.
- Maximum temperature of 95°C for water and 160°C for oil.
- Automatic cooling water supply and mould purging facility as standard.
- Upon request, it can be built to comply with worldwide electrical safety standards (For example : CE, UL, CSA, JIS etc.).



STM-1207-W/O Inner Structure



System Flow Diagram (indirect cooling)

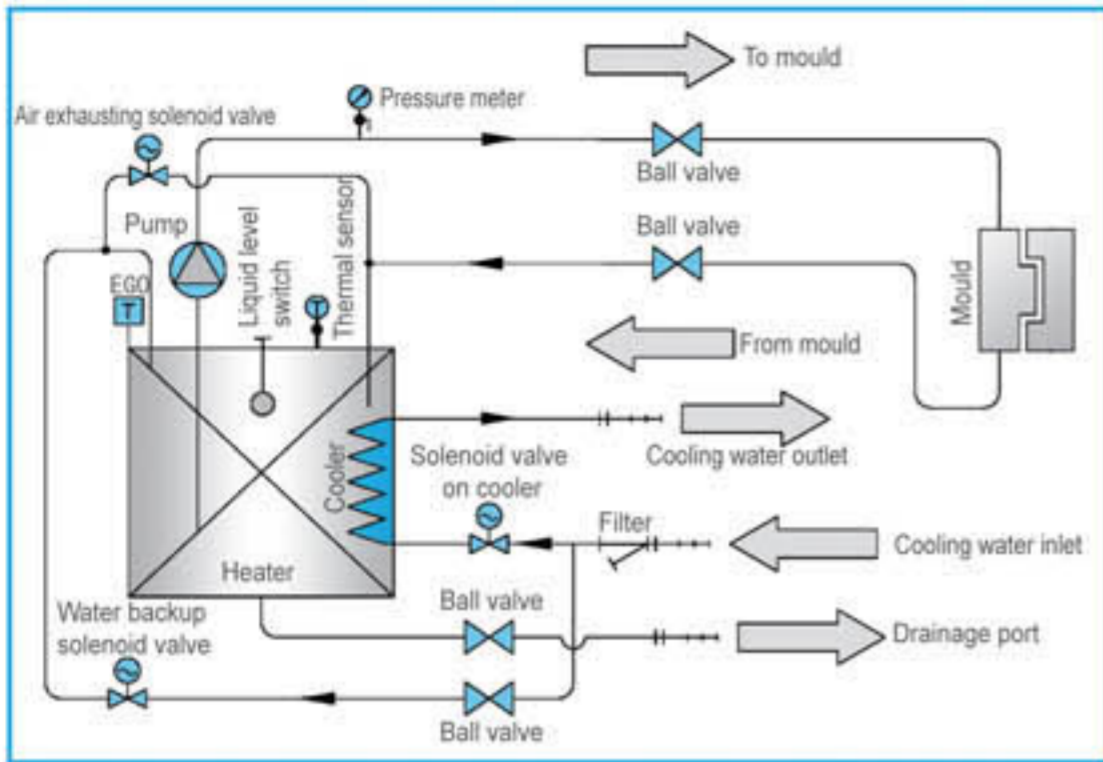

High temperature water returns to the machine and then be pressured by pump to the heaters. After being heated, water will be forced to mould and continue the circle. In the process, if the temperature is too high, the system will activate the solenoid valve to let cooling water cool down the temp. directly till the water temp. is down to the system requirement. If the temp. keep rising and reach to the set point of EGO, the system will alarm and stop operation. The system will have low pressure alarm and stop working if cooling water pressure doesn't reach set point.

Applications

Mainly used for heating up and maintaining a constant mould temperature or in other fields that require a constant flow of hot oil / water.

Specifications

Model	Max. Temp.	Heater (kW)	Pump (kW)	Max. Pump Flow (L/min)	Pump Pressure (bar)	Heating Tank	Heating Tank Volume (L)	Cooling Method	Mould Coupling* (inch)	Inlet/Outlet (inch)	Dimensions (mm) (H x W x D)	Weight (kg)
STM-607-W/O	W: 95 °C O: 160 °C	6	0.55	55	3.4	1	12	Indirect cooling	3 / 8" (2 x 2)	3/4" / 3/4"	820 x 312 x 725	75
STM-907-W/O		W: 9 O: 6	0.55	55	3.4	1	16		3 / 8" (2 x 2)	3/4" / 3/4"	815 x 360 x 860	84
STM-1207-W/O		W: 12 O: 6	0.55	55	3.4	1	16		3 / 8" (2 x 2)	3/4" / 3/4"	815 x 360 x 860	85

Note: 1) Pump testing conditions: Power of 50 / 60Hz, purified water in 20 °C.
(± 10 % is tolerable for either max. flowrate or max. pressure).
2) " * " Stands for options.
3) Power supply: 3Φ, 230 / 400 / 460 / 575V, 50 / 60 Hz.

Model Selection Guide

Mould Clamping Force (T)	Moulding Capacity (kg / hr)	Pump Flow (L / min)
Below 50	Below 6	27
50~100	6~12	
100~200	12~25	

Mould Clamping Force (T)	Moulding Capacity (kg / hr)	Pump Flow (L / min)
200~300	25~40	40
300~650	40~80	58
Above 650	Above 80	100

We reserve the right to change specifications without prior notice.

SHINI PLASTICS TECHNOLOGIES, INC.

Corporate Strategic Center
Overseas Business Department:
Dalang, Dongguan, Guangdong, China
Tel: (0769) 8111 6600
Fax: (0769) 8111 6611
Email: shini@shini.com