

Oil Heaters

STM series oil heaters have both the standard and high temperature models, which are used to heat up the mould and maintain temperature, although they can be used in other similar applications. High temperature oil from the mould is returned to the cooling tank and cooled by indirect cooling. It is then pressurised by the high - pressure pump, sent to the heating tank and finally to the mould with a constant temperature. With our optimised design, It can reach a maximum of 200°C and the OMRON temperature controller can maintain an accuracy of ± 1 °C.



STM-910-D



STM-910

Features

- P.I.D. multi - stage temperature control system can maintain a mould temperature with accuracy of ± 1 °C.
- Adopt high efficiency high temperature pump with great pressure and stable performance.
- Multiple safety devices can automatically detect abnormal performance and indicate this via visible alarm.
- Attractive appearance, easy to access and maintain.
- Pipe heaters are made of stainless steel.
- For standard STM, the heating temperature can reach 200 °C, while for STM - HT, it can reach 300 °C.
- Inside tank of STM - HT is made of high pressure resistance stainless steel to prevent any explosion.
- Water manifolds, Teflon hose and Transfer oil are optional.
- Upon request, it can be built to comply with worldwide electrical safety standards (For example : CE, UL, CSA, JIS etc.).



STM-1215HT



System Flow for STM and STM-907HT

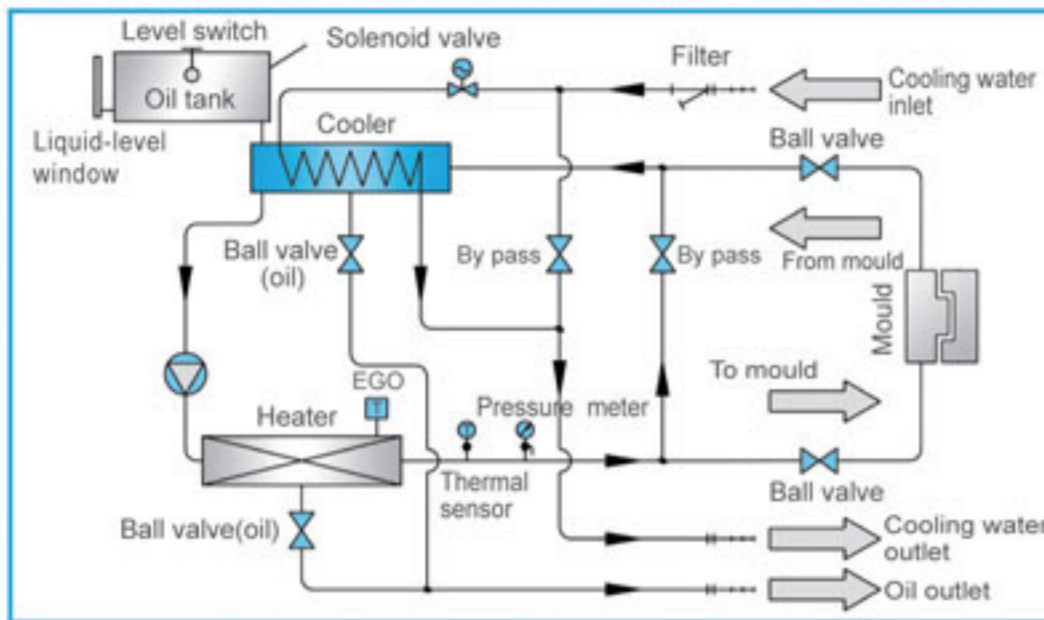

The high temperature oil returns to the machine and then be pressured by pump to the heaters. After being heated, oil will be forced to the mould and continue the circle. In the process, if the temp. is too high, the system will activate the solenoid valve to let cooling water cool down the temp. indirectly until the temp. is down to the system requirement. If the temp. keeps increasing and reaches to the set point of EGO, the system will alarm and stop operation. The system will have low level alarm and stop working if oil level falls down below the set point.

System Flow for STM-1215 / 2440HT

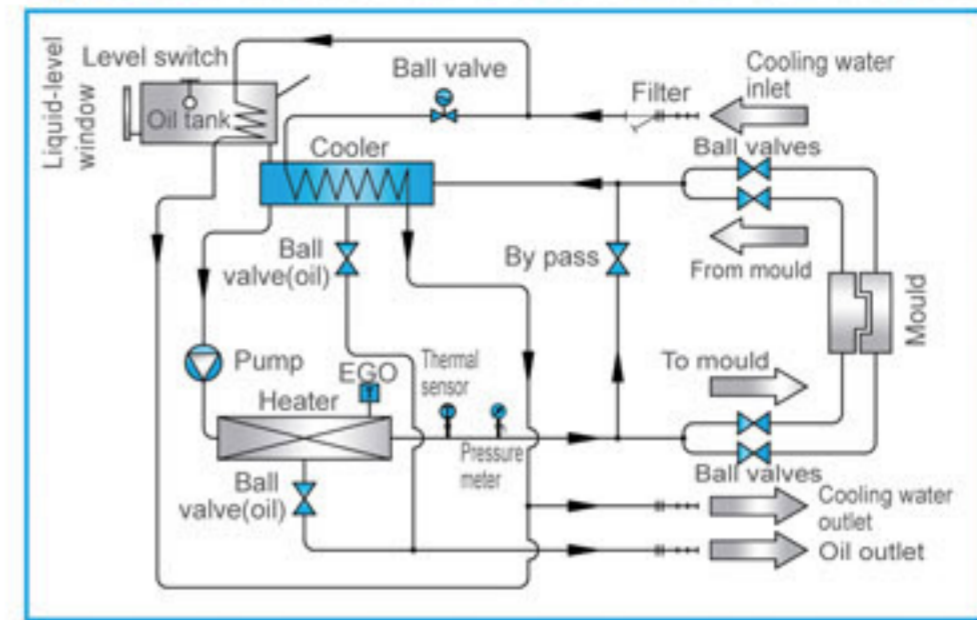

The high temperature oil returns to the machine and then be pressured by pump to the heaters. After being heated, oil will be forced to the mould and continue the circle. In the process, if the temp. is too high, the system will activate the solenoid valve to let cooling water cool down the temp. indirectly until the temp. is down to the system requirement. If the temp. keeps increasing and reaches to the set point of EGO, the system will alarm and stop operation. The system will have low level alarm and stop working if oil level falls down below the set point.

Applications

Mainly used for heating up and maintaining a constant mould temperature, or in other fields that require a constant flow of hot oil.

Specifications

Model	Max. Temp.	Pipe Heater (kW)	Pump Power (kW) (50 / 60Hz)	Max. pump Flow (L / min) (50 / 60Hz)	Max. pump Pressure (bar) (50 / 60Hz)	Heating Tank Number	Main / Sub. Oil Tank (L)	Cooling Method	Mould Coupling* (inch)	Inlet/Outlet (inch)	Dimensions (mm) (H x W x D)	Weight (kg)
STM-607	200 °C	6	0.55 / 0.63	27 / 30	3.8 / 5	1	6 / 3.2	Indirect	3 / 8" (2 x 2)	3/4" / 3/4"	635 x 280 x 740	65
STM-607-D		6 x 2	2x0.55 / 2x0.63	2x27 / 2x30	3.8 / 5	2	2 x 6 / 2 x 3.2		3 / 8" (4 x 2)	3/4" / 3/4"	655 x 560 x 740	130
STM-910		9	0.75 / 0.92	42 / 50	5.0 / 6.4	1	6 / 3.2		3 / 8" (2 x 2)	3/4" / 3/4"	635 x 280 x 740	70
STM-910-D		9 x 2	2x0.75 / 2x0.92	2x42 / 2x50	5.0 / 6.4	2	2 x 6 / 2 x 3.2		3 / 8" (4 x 2)	3/4" / 3/4"	655 x 560 x 740	140
STM-1220		12	1.5 / 1.9	74 / 84	6.2 / 7.2	1	6.8 / 11.8		3 / 8" (4 x 2)	1" / 1"	795 x 340 x 845	100
STM-2440		24	2.8 / 3.4	90 / 90	8.0 / 10.2	2	11 / 16		1" (1 x 2)	1" / 1"	900 x 390 x 935	145
STM-3650		36	4 / 4	100 / 100	8.0 / 8.0	3	14 / 16		1 1/4" (1 x 2)	1 1/4" / 1 1/4"	900 x 385 x 980	155
STM-907-HT	300 °C	9	0.5 / 0.63	28 / 34	4.8 / 6.5	1	6 / 6	Indirect	3 / 8" (2 x 2)	3/4" / 3/4"	695 x 280 x 740	75
STM-1215-HT		12	1.0 / 1.1	58 / 63	5.8 / 6.8	1	6.8 / 16		1" (1 x 2)	1" / 1"	795 x 340 x 820	100
STM-2440-HT		24	2.8 / 3.43	100 / 100	8 / 9	2	16 / 25		1" (1 x 2)	1" / 1"	1050 x 515 x 910	190

Note: 1) " D " stands for dual - heating zones. " HT " stands for high temperature model.
 2) Pump testing standard: Power of 50 / 60Hz, purified water at 20°C. (There is ± 10% tolerance for either max. flowrate or max. pressure).
 3) " * " Stands for options.
 4) Power supply: 3Φ, 230 / 400 / 460 / 575V, 50 / 60Hz.

Model Selection Guide

Mould Clamping Force (T)	Moulding Capacity (kg / hr)	Pump Flow (L / min)
Below 50	Below 6	27
50~100	6~12	
100~200	12~25	

Mould Clamping Force (T)	Moulding Capacity (kg / hr)	Pump Flow (L / min)
200~300	25~40	40
300~650	40~80	58
Above 650	Above 80	100

We reserve the right to change specifications without prior notice.

SHINI PLASTICS TECHNOLOGIES, INC.

Corporate Strategic Center
 Overseas Business Department:
 Dalang, Dongguan, Guangdong, China
 Tel: (0769) 8111 6600
 Fax: (0769) 8111 6611
 Email: shini@shini.com